

AQUATIC ADA AND YOUR FACILITY



*Prepared by Ronald Ford with thanks to
Keiser University's Chair of Aquatic Engineering –
Connie Sue Centrella*

DISCLAIMER

DON'T SHOOT THE MESSENGER!

This program is for training purposes only.

- To be sure you are in compliance check these references:
 - www.ADA.gov
 - <http://www.access-board.gov/ada-aba/final.pdf>
 - Manufacturers of access products websites



50 MILLION PEOPLE ARE DISABLED

Figure 2.
**Disability Prevalence and the Need for Assistance
by Age: 2002**

(Percent of all people in age group)

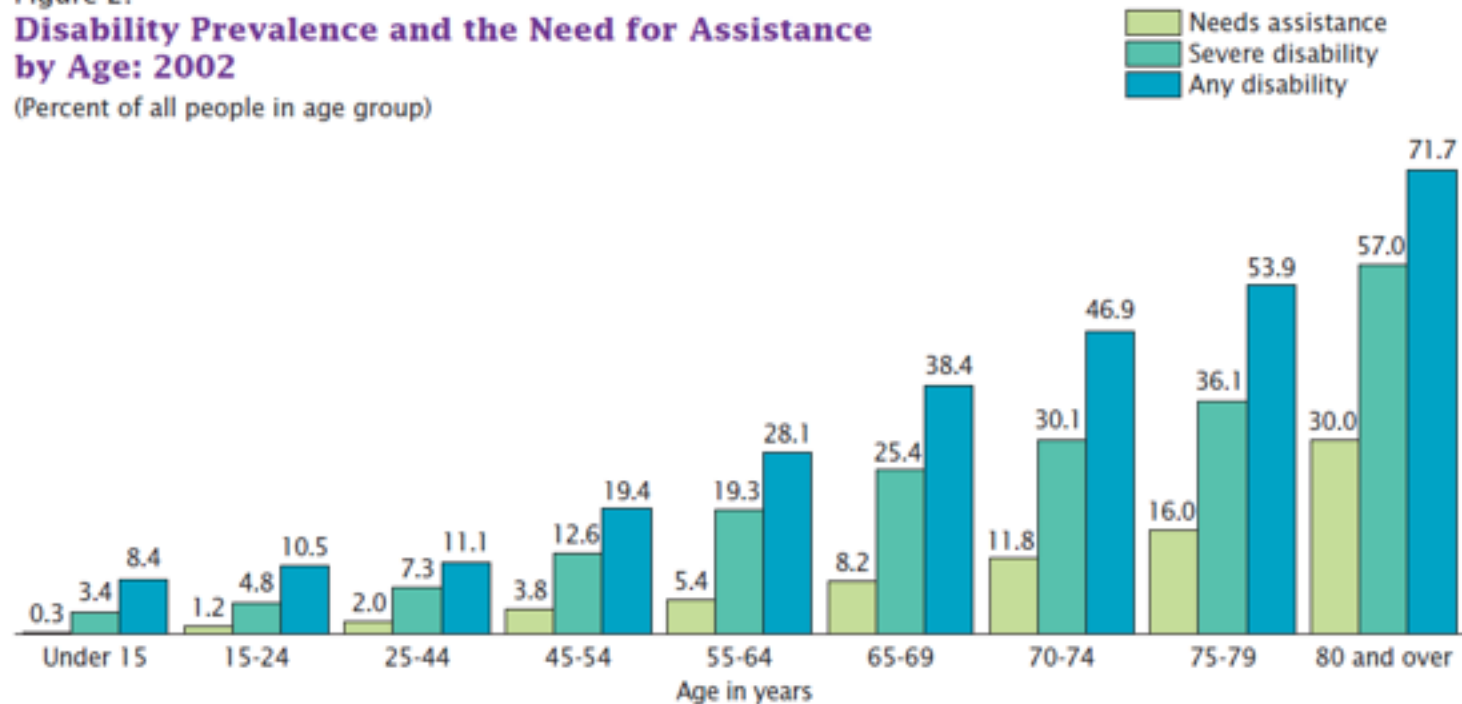

Source: U.S. Census Bureau, Survey of Income and Program Participation, June–September 2002.

Slide Courtesy of S. R. Smith and U.S. Census Bureau

AMERICANS WITH DISABILITIES ACT



18% of population

- 50 million disabled
- Civil rights law
 - Discrimination based on disability
 - Provide reasonable accommodation
 - Department of Justice enforces the ADA

GOAL

Get people out of homes

**Eliminate
architectural barriers**

Everyone benefits

- Inclusion into society
 - Become viable parts of mainstream America

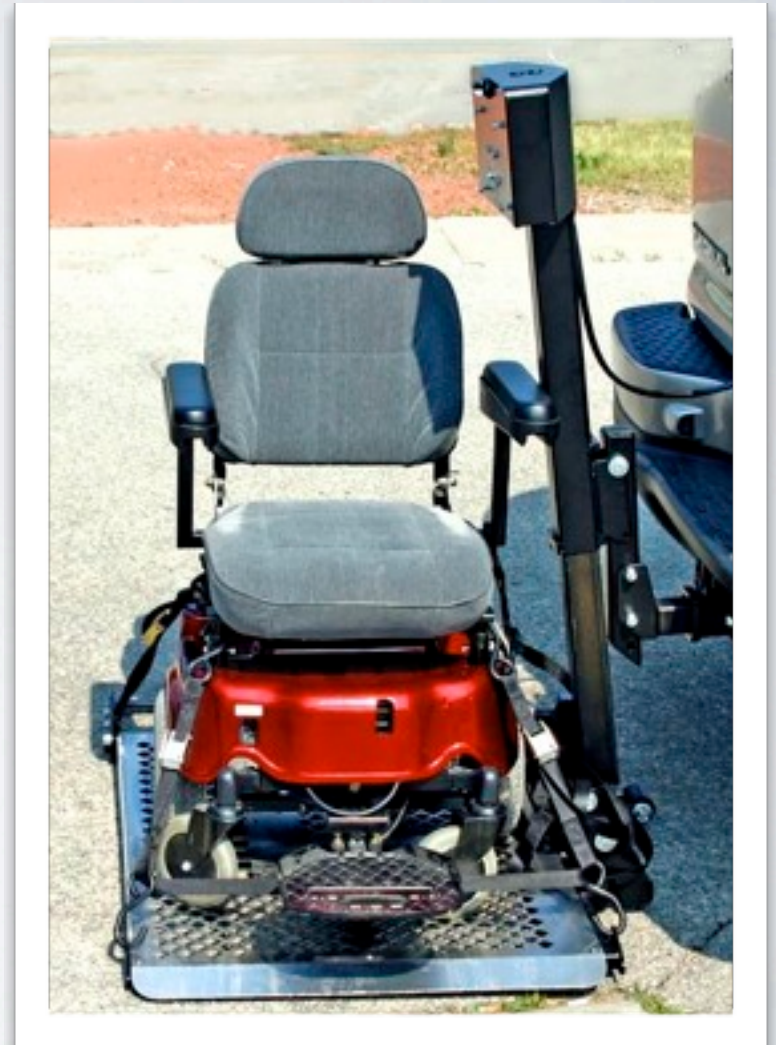

HISTORY AND BACKGROUND

Original ADA signed into law on July 26, 1990

2004- Access Board issued Pool Guidelines

July 2010 Guidelines became regulations

Effective March 15, 2011

Compliance required by March 15, 2012

Guidelines are now the law!

U.S. ACCESS BOARD

Responsible for defining accessibility guidelines

- Handicap hotel rooms
- Parking spaces

Intent was to make every swimming pool accessible

Spent 10 years working on recreational facilities



ACCESSIBILITY

**Public Entities and
Transportation (Title II)**

**Public Accommodations and
Commercial (Private) Facilities
(Title III)**

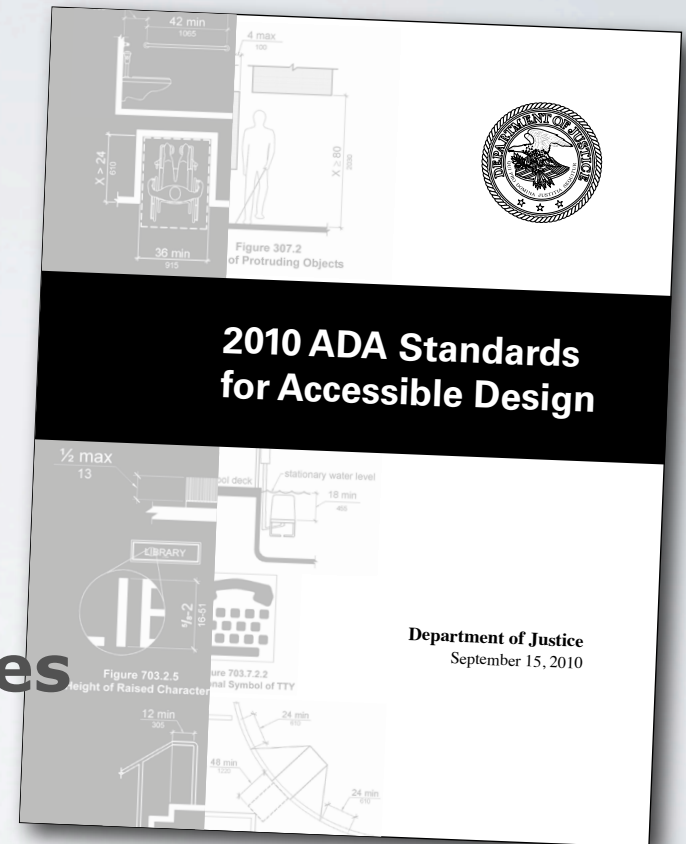

WHAT IS A PUBLIC ACCOMMODATION

Title II – Public Entity

- Any activity, service, program or facility owned by any government agency



WHAT IS A PUBLIC ACCOMMODATION

Title III – Public Accommodation

- Commercial facilities or private companies
 - Hotels, Motels, Fitness Centers, Water Parks, Time share units
- Charging a fee

EXCLUSIONS

Title II facilities

- Alter historic nature of building
- Undue financial hardship



EXCLUSIONS

Title III facilities

- Modifications are not achievable

Not Included: (exceptions)

- Private Residences
- Apartments, Condos
- Beaches, Rivers and Lakes



ENFORCEMENT

Lawsuits initiated for non-compliance

- Court order requires remedies

Building Code review prior to issuing license

- No federal grant to municipalities
- No Issuance of Certificate of Occupancy
- Action can be taken by code officials
 - Health Departments
 - Building Code Departments

ADA ANALYSIS

Pool strictly limited to residents or members?

- exempt

Advertisement of membership to public?

- must comply

Pool rented out for events?

- Must comply



ADA ANALYSIS

Does pool generate any income?

- Must comply

Open for swim meets?

- Must comply

Open for swim lessons?

- For outside attendees; if only for residents do not have to comply.



**Must
Comply**



**Must
Comply**



Exempt

Type	Primary		Secondary		
Means of Access	Pool Lift	Sloped Entry	Transfer Wall	Transfer System	Stairs
Swimming Pool less than 300 linear feet (one access)	✓	✓			
Swimming Pool more than 300 linear feet (two access)	✓	✓	✓	✓	✓
Wave action, lazy river, and other pools where there is only one means of entry	✓	✓		✓	
Wading Pool		✓			
Spas	✓ Primary		✓ Primary	✓ Primary	

PERMITTED ACCESS

Type depends on design

Primary

- Pool Lifts
- Sloped entries (ramps)

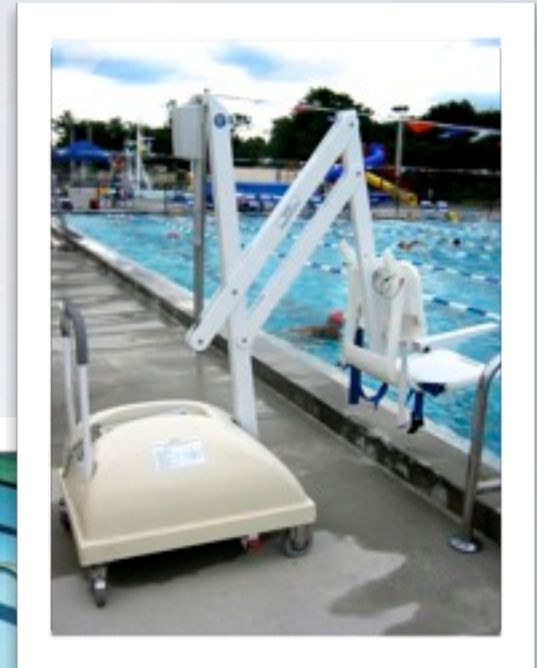
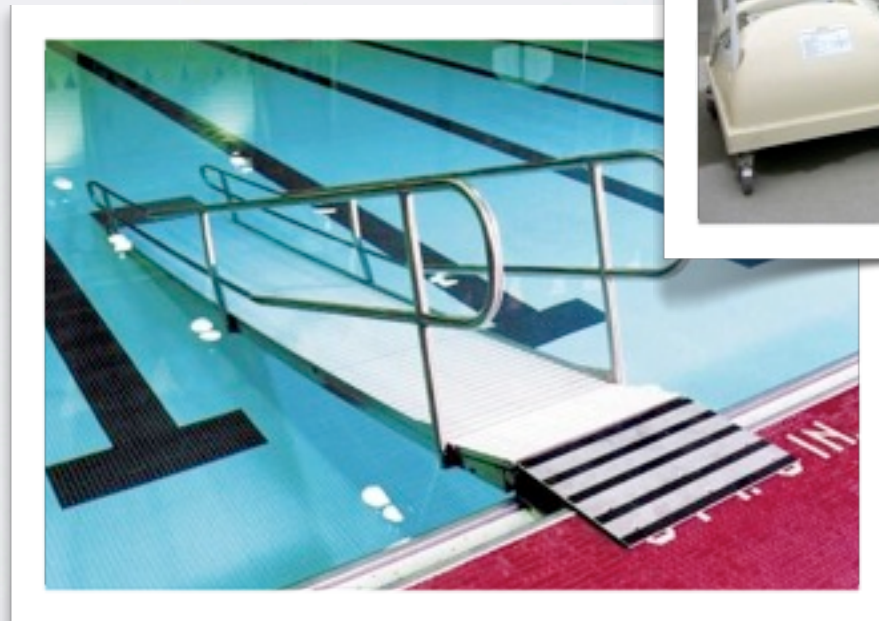

PERMITTED ACCESS

Type depends on design

Secondary

- Transfer Walls
- Transfer systems
- Accessible Stairs

All installations by March 2012

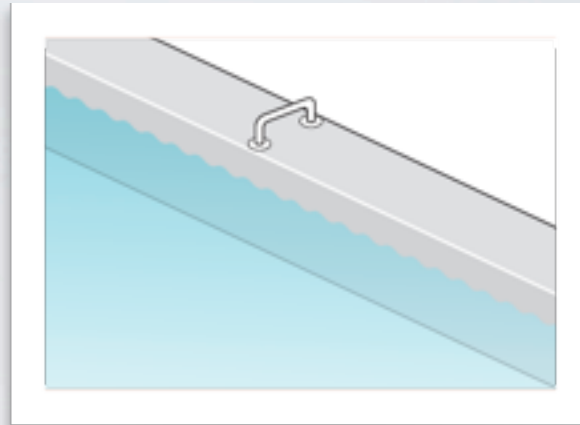

POOL LIFTS

Capable of independent operation

- Located in shallow water less than 48"
- Minimum of 16 inch wide seat
- 16 inch from deck to top of seat
- Capacity of 300 pounds
- Must submerge user 18" below water level
- Must have foot rests
- Clearance for transfer

SLOPED ENTRIES (RAMPS)

- Minimum width of 36"
- Slope 1:12
- Must extend to depth of 24 inches to 30 inches below water level
- Must have handrails (except in wading pools)
- Must provide a mobile aquatic wheelchair

AQUATIC WHEELCHAIR



TRANSFER WALLS

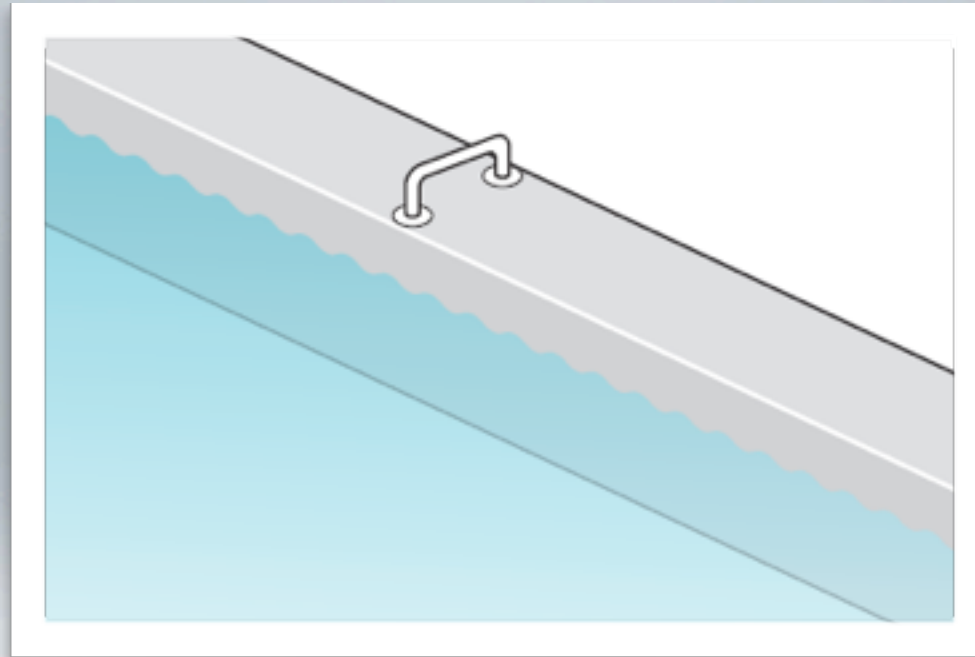

A wall that allows a person to transfer from wheelchair onto the pool wall

TRANSFER SYSTEMS

Transfer platform

- Series of transfer steps



SWIMMING POOL SPECIFIC REQUIREMENTS

Less than 300 linear feet of wall total

- One primary entry only
 - Swim lift or sloped entry ramp

Greater than 300 linear feet total

- Two means
 - One must be primary

Wave pools, leisure rivers, etc

- User limited to one area of access- only one needed

WADING POOL SPECIFICS

Must have one means of access

- **Must be a sloped entry ramp**
 - Extend to deepest part of wading pools
 - Handrails are not required



SPA SPECIFICS

Inground or portable spas must comply

- Must have one means of entry
 - Lift (primary)
 - Transfer wall (primary)
 - Transfer system (primary)
- Cluster of spas in one area
 - Only one has to be ADA compliant
 - One compliant per cluster

FINANCIAL ASSISTANCE

Special Tax credit is available

- \$1M gross revenue,
- Less than 30 employees
- Offset 50% cost up to \$5,000

DOJ ADA Tax Incentive Packet

Internal Revenue Service

QUESTIONS?

To be sure you are in compliance check

- www.ADA.gov
- <http://www.access-board.gov/ada-aba/final.pdf>
- Manufacturers of access products websites